

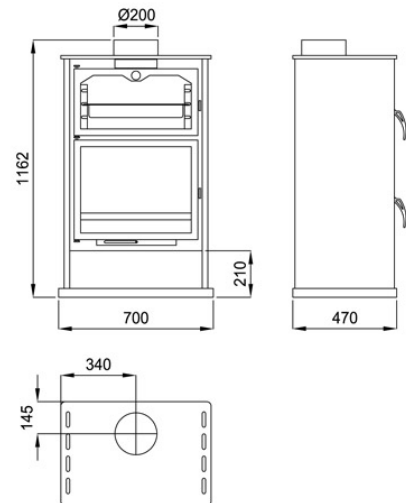

10

Features

- Surround System Oven
- Double Chamber System
- Clean Glass System
- Heating power: 10kw
- Efficiency (%): 76%
- Consumption (kg/h): 3kg/h
- Heating capacity (m3): 250m3
- Metalic inside
- Manufactured in cast-iron and steel
- Weight (kg): 140kg
- Smoke exit tube diameter (mm): 200mm
- Useful chamber measures: 530x369x400mm
- Useful oven measures: 500x250x400mm
- Maximum logs size (cm): 55cm



Medida Boca Util: 530 x 369 x 400 mm
Medida Horno Util: 500 x 250 x 400 mm

Given the continued improvement of our products and improving our manufacturing process, size, aesthetics and product specifications are subject to change without prior notice from our company.

www.bronpi.com

