

KENIA-110 CLASSIC

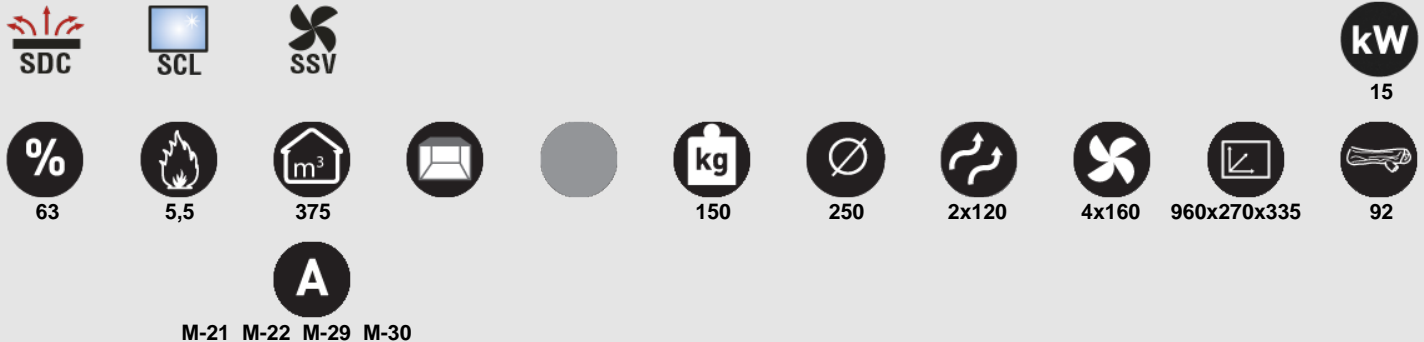

Features

- Double Combustion System
- Clean Glass System
- Security System in Fans
- Heating power: 15kw
- Efficiency (%): 63%
- Consumption (kg/h): 5,5kg/h
- Heating capacity (m3): 375m3
- Ceramic inside
- Manufactured in steel
- Weight (kg): 150kg
- Smoke exit tube diameter (mm): 250mm
- Air channel (diameter and exit tube number): 2x120
- Forced ventilation: 4x160
- Useful chamber measures: 960x270x335mm
- Maximum logs size (cm): 92cm
- Compatible accesories not included: M-21; M-22; M-29; M-30

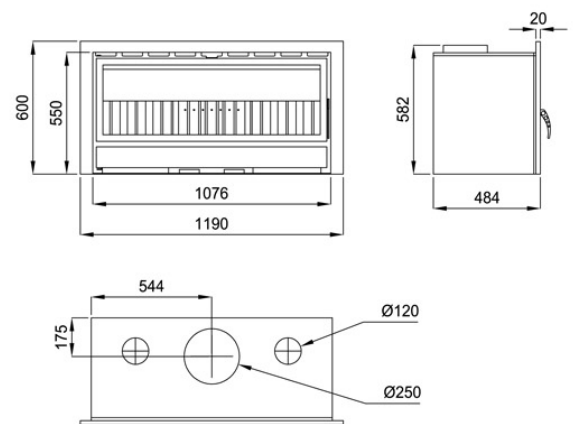

Medida Boca Util: 960 x 270 x 335 mm

Given the continued improvement of our products and improving our manufacturing process, size, aesthetics and product specifications are subject to change without prior notice from our company.

www.bronpi.com



©Bronpi Calefacción, S.L. reserves all rights to the images that appear in this document. You may not reproduce or distribute part or all of the photographs and as the text. Both the brand as distinctive symbols are the exclusive property of the company. Violators will be prosecuted according to law.