

MADRID

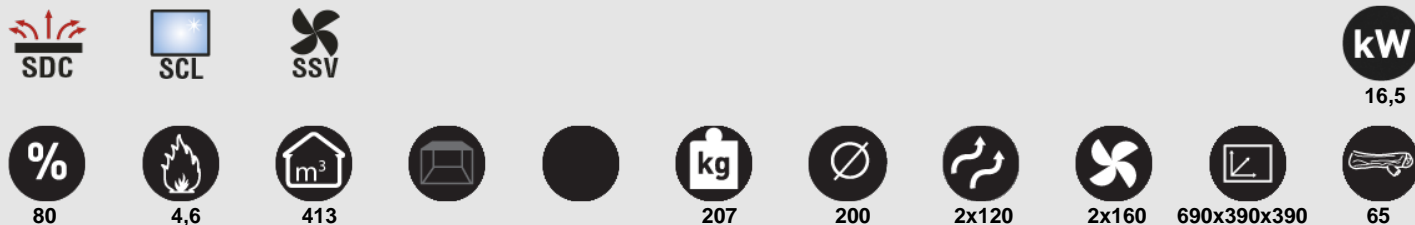

Features

- Double Combustion System
- Clean Glass System
- Security System in Fans
- Heating power: 16,5kw
- Efficiency (%): 80%
- Consumption (kg/h): 4,6kg/h
- Heating capacity (m3): 413m3
- Cast-iron inside
- Manufactured in cast-iron
- Weight (kg): 207kg
- Smoke exit tube diameter (mm): 200mm
- Air channel (diameter and exit tube number): 2x120
- Forced ventilation: 2x160
- Useful chamber measures: 690x390x390mm
- Maximum logs size (cm): 65cm

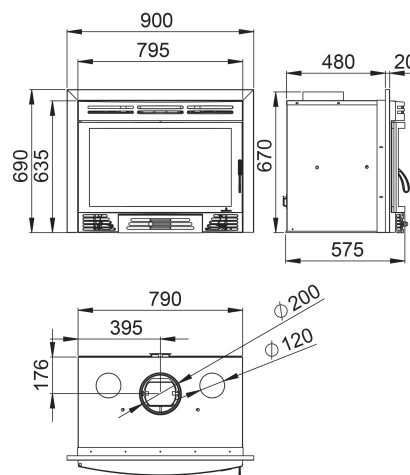

Given the continued improvement of our products and improving our manufacturing process, size, aesthetics and product specifications are subject to change without prior notice from our company.

www.bronpi.com

