

# HUELVA C



16



76



4,9



400



146



200



538x310x600



60

## Features

- Clean Glass System
- Heating power: 16kw
- Efficiency (%): 76%
- Consumption (kg/h): 4,9kg/h
- Heating capacity (m3): 400m3
- Metalic inside
- Manufactured in cast-iron and steel
- Weight (kg): 146kg
- Smoke exit tube diameter (mm): 200mm
- Useful chamber measures: 538x310x600mm
- Maximum logs size (cm): 60cm

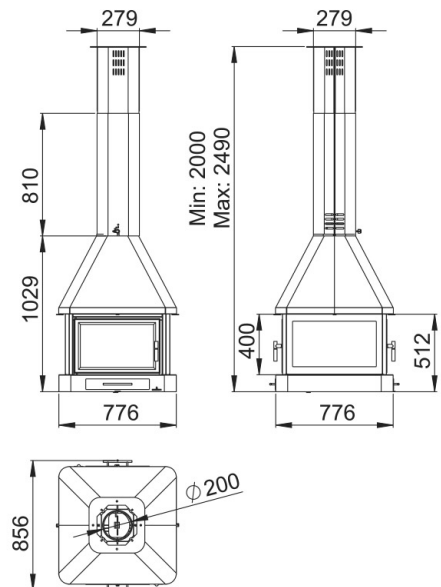

Given the continued improvement of our products and improving our manufacturing process, size, aesthetics and product specifications are subject to change without prior notice from our company.

[www.bronpi.com](http://www.bronpi.com)

