

# SENA PLUS



SCL



SBE



12,5



79



3,8



313



78



150



585x250x304



60

## Traits

- Système Vitre Propre
- Système faibles émissions
- La puissance de chauffage: 12,5kw
- Rendement (%): 79%
- Consommation(kg/h): 3,8kg/h
- Volume chauffé (m3): 313m3
- Intérieur en vermiculite
- Fabriqué en fonte et acier
- Poids (kg): 78kg
- Diamètre sortie de fumée (cm): 150cm
- Mesures de l'entrée utile de la chambre: 585x250x304mm
- Taille maximum des troncs: 60cm

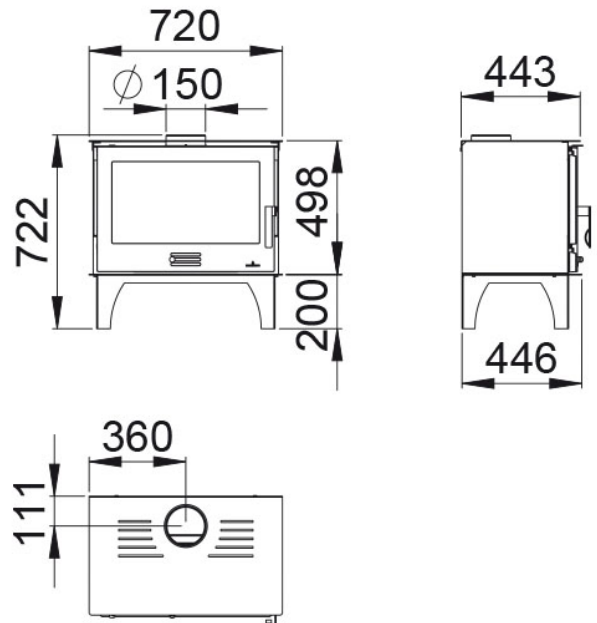

Compte tenu de l'amélioration continue de nos produits et l'amélioration de notre processus de fabrication, de taille, l'esthétique et les spécifications des produits sont sujets à changement sans préavis de notre société.

[www.bronpi.com](http://www.bronpi.com)

