

# HUESCA



|  |   |  |   |   |  |   |  |   |
|--|---|--|---|---|--|---|--|---|
|  SDC |  SCL |  |   |   |  |   |  kW |   |
|  |   |  |   |   |  |   | 11   |   |
|  %   |      |  m <sup>3</sup> |  |  |  kg |  |      |  |
| 76   | 3,4   | 275  |   |   | 106  | 150   | 608x313x303  | 64  |

## Features

- Double Combustion System
- Clean Glass System
- Heating power: 11kw
- Efficiency (%): 76%
- Consumption (kg/h): 3,4kg/h
- Heating capacity (m3): 275m3
- Vermiculite inside
- Manufactured in cast-iron and steel
- Weight (kg): 106kg
- Smoke exit tube diameter (mm): 150mm
- Useful chamber measures: 608x313x303mm
- Maximum logs size (cm): 64cm

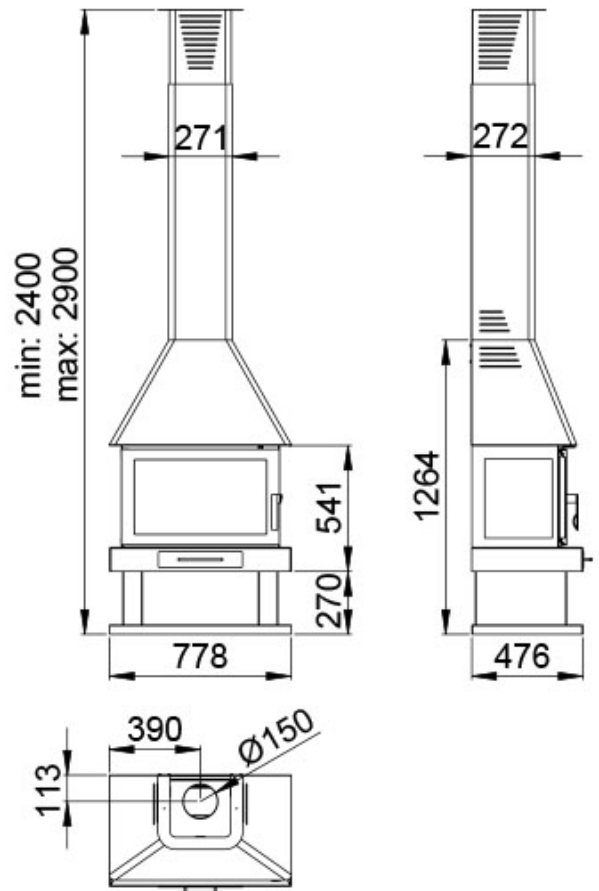

Given the continued improvement of our products and improving our manufacturing process, size, aesthetics and product specifications are subject to change without prior notice from our company.

[www.bronpi.com](http://www.bronpi.com)

