

LONDRES



76

6,4

525

135

200

860x270x380

85

21

M-7 M-8 M-9 M-10

Caratteristiche

- Sistema Doppia Combustione
- Sistema di Vetro Pulito
- Sistema di Basse Emissioni
- Potenza di riscaldamento: 21kw
- Rendimento (%): 76%
- Consumo (kg/h): 6,4kg/h
- Volume riscaldabile (m3): 525m3
- Interni vermiculite
- Prodotto in acciaio
- Peso (Kg): 135kg
- Diametro di uscita di fumi (mm): 200mm
- Le misure della bocca utile della camera: 860x270x380mm
- Massima misura tronchi (cm): 85cm
- Accessori compatibili non inclusi: M-7; M-8; M-9; M-10

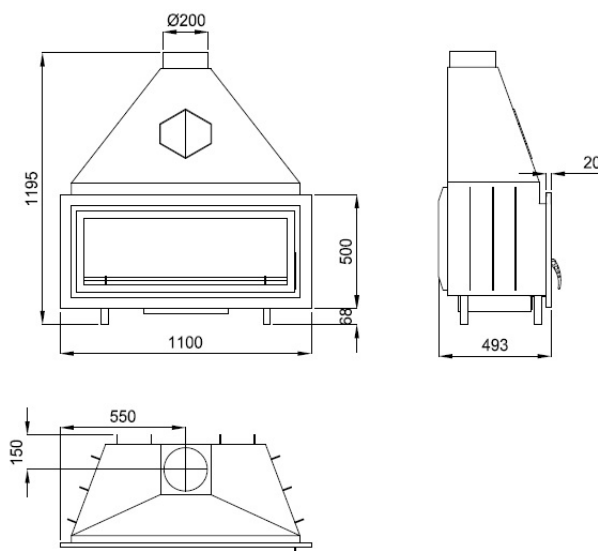

Medida Boca Util: 860 x 270 x 380 mm

Dato il continuo miglioramento dei nostri prodotti e migliorare il nostro processo di produzione, dimensioni, estetica e le specifiche dei prodotti sono soggette a modifiche senza preavviso da parte nostra azienda.

www.bronpi.com



© Bronpi Calefacción, S.L. si riserva tutti i diritti per le immagini che appaiono in questo documento. Non è possibile riprodurre o distribuire tutto o in parte le fotografie e come il testo. Sia il brand come segni distintivi sono di proprietà esclusiva della Bronpi. I trasgressori saranno puniti perseguendo a noi per legge.