

LONDRES



SDC



SCL



SBE



21



76



6,4



525



135



200



860x270x380



85



M-8

Features

- Double Combustion System
- Clean Glass System
- Low Emissions System
- Heating power: 21kw
- Efficiency (%): 76%
- Consumption (kg/h): 6,4kg/h
- Heating capacity (m3): 525m3
- Vermiculite inside
- Manufactured in steel
- Weight (kg): 135kg
- Smoke exit tube diameter (cm): 200cm
- Useful chamber measures: 860x270x380mm
- Maximum logs size (cm): 85cm
- Compatible accesories not included: M-8

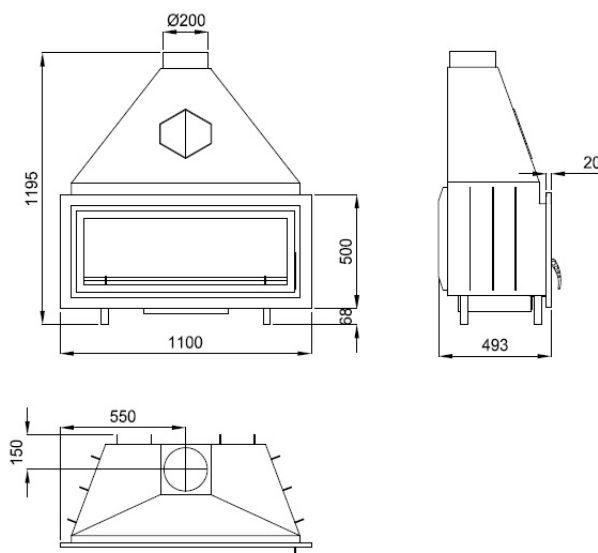

Medida Boca Util: 860 x 270 x 380 mm

Given the continued improvement of our products and improving our manufacturing process, size, aesthetics and product specifications are subject to change without prior notice from our company.

www.bronpi.com



©Bronpi Calefacción, S.L. reserves all rights to the images that appear in this document. You may not reproduce or distribute part or all of the photographs and as the text. Both the brand as distinctive symbols are the exclusive property of the company. Violators will be prosecuted accordingly.